

Different considerations regarding the usage of tool steel UNIVERSAL.

MACHINING:

The normal sequence when machining a die or punch with this material, should be:

-Pre-machining, removing stock in annealed condition, leaving some material excess to correct deformations during heat treatment. The amount of excess material is a function of the geometry and heat treatment applied (which in turn depends on the chosen heat treating shop, the equipment they possess and procedures they employ). While gaining experience, leaving the same amount of material as for 1.2379 (AISI D2), will have the user on the safe side since the deformation will always be smaller and with less distortion. For machining parameters consult the tables below.

-Stress relieving, by holding the pre-machined blocks in a furnace at 650 °C during 2 hours, and then cool very slowly, leaving the blocks inside the furnace.

-Heat treatment (please refer to the Heat Treatment chapter).

-Finish-machining, high speed machining or grinding to final dimensions. For machining parameters consult the tables below.

-Stress relieving temper cycle, a 2h temper cycle should be applied at a temperature 15°C below the highest temper temperature previously applied (during heat treatment, so normally 505 °C for high wear heat treatment and 540°C for high toughness heat treatment).

Annealed condition:

OPERATION		Cutting Speed [m / minute]	Feed [mm / tooth]	Depth of Cut [mm]	
Face Milling	Roughing	110-150	0.2-0.4	2- ^{**}	
	Finishing	110-180	0.1- [*]	0.1- [*]	
End milling	Carbide tooling	50-90	Feeds for all types of tooling		
			Tool Diameter [mm]	Roughing Feed [mm / tooth]	Finishing Feed [mm / tooth]
	Coated HSS	22-30	2 – 6	0.1-0.2	0.02-0.1
			6 – 14	0.2-0.4	0.03-0.3
	HSS tooling	10-20	> 14	0.2-0.6	0.03-0.3

*- Depending on desired roughness.

**- Depending on machine rigidity.

Hardened condition. High Speed Machining:

Most clients are using different parameters depending on the machine and type of tooling they employ. Use the following table as a general reference only. In all cases PCBN or PCBN-cermets were used, cutter diameters ranging from 12 to 40mm, rake angle normally being 0° for roughing and up to –20° for finishing.

OPERATION	Cutting Speed v_c [m/min]	Feed f [mm/tooth]	Axial depth of cut a_p [mm]	Radial width of cut a_e [mm]
Roughing	60 – 200	0.1 – 0.5	1.2 - 2	0.5 – 0.75
Ball end milling	180 – 230	0.05 – 0.12	0.2 – 0.6	0.2 – 0.5
Drilling	100 - 200	0.006 – 0.012	Cutting length expected: 60 mm	

Grinding:

MATERIAL COND. PROPERTY	HARDENED at 63,5 HRc	HARDENED at 62 HRc	ANNEALED
Abrasive type	5 SG – 5 TG SG – TG	3TG – 3SGV	5GB – 5GA
Hardness	E – H	F – I	H - Jot
Grain size	70 – 80	50 – 60	36 – 50
Binding material	Glassy	Glassy	Glassy
Cooling fluid	Semi-synthetic oil	High pressure oil	High pressure oil
Flow	MIN : 80 l/min.	Min : 60 l/min.	Min : 40 l/min.
Pressure	MIN: 10 bar	MIN: 8 bar	MIN: 6 bar
Flow Incidence	Contact line	Contact line	Contact line
Cutting speed	35 – 50 m/s	35 – 50 m/s	35 – 50 m/s
Depth of Cut	0.01 – 0.02 mm	0.02 – 0.05 mm	0.05 – 0.10 mm
Feed speed	10 m / min.	25 m / min.	25 m / min.
Expected Roughness.	0.30 – 0.60 Ra.	0.50 – 0.80 Ra.	0.50 – 0.80 Ra.

HEAT TREATMENT:

HARDENING :

Preheat slowly until the core reaches a temperature of 840-880 °C letting the temperature homogenize, austenitize at a temperature of 1070 °C, homogenize temperature, transform during 40-45 minutes, and cool down with N₂ at a speed equivalent to ventilated air cooling.

TEMPERING :

Two different tempering strategies are most commonly applied:

- For applications requiring only high wear resistance: 3 tempering cycles with a holding time of 2 hours at 520 °C each have to be applied. Hardness: 63,5 +/-2.
- For applications requiring acceptable wear resistance and high toughness: 2 tempering cycles with a holding time of 2 hours at 540 °C each, and a third 2 hours tempering cycle at 555 - 560 °C have to be applied. Hardness: 62 +/-2.

WELDING:

Welding of UNIVERSAL is easier than that of 1.2379 under all circumstances. Primarily because it shows less tendency to cracking, and blowing. So it is possible to employ the same techniques regularly employed in your facilities for the welding of 1.2379. In all cases the surfaces of the die to be welded should be thoroughly cleaned and dry.

Joining and surfacing hardened material:

When using the following filler materials for joining or bed surfacing, breaking occurs on the filler material and not on the heat affected zone, for UNIVERSAL, HWS and 1.2379, so the mechanical resistance of the joint is that of the filler material:

EutecTrode 680S, EutecTrode 4080, EutecTrode 2222M (only one or two bed layers of this material are recommended because mechanical resistance is low), KD 29-9 E32, Nicrotec 6800S.

The welding procedure should be as follows:

Weld the piece while keeping it at a temperature between 350-500 °C, reheat if necessary. After every weld bead, conduct a post weld upsetting to counter tensions originating from solidification and cooling down. After welding the piece should be subjected to one or two tempering cycles (depending on the geometry of the piece and the amount of welding conducted) at 15 °C below the maximum tempering temperature applied during heat treatment of the die.

As hard materials the following ones have been tried with good results: EutecTrode 2 R, KD-63, KD-64, KD-700. For all of them only one layer is recommended. The cracking tendency depends on the bed layer applied and the welding procedure, and is almost independent of the base material.

Joining and surfacing hardened material on punches or dies for shaping AHSS:

Some special considerations have to be made when repairing a die which shapes AHSS through welding. That is specially the case when dealing with very high specific pressures due to great sheet mechanical resistance (MART sheets, CP1000, or even TRIP 800), or big sheet thickness, since sinking in the welded region can occur. Most electrodes and filler materials employed for welding cold work tool steels act as alloying diffusers, being the structure of the welded zone as follows:

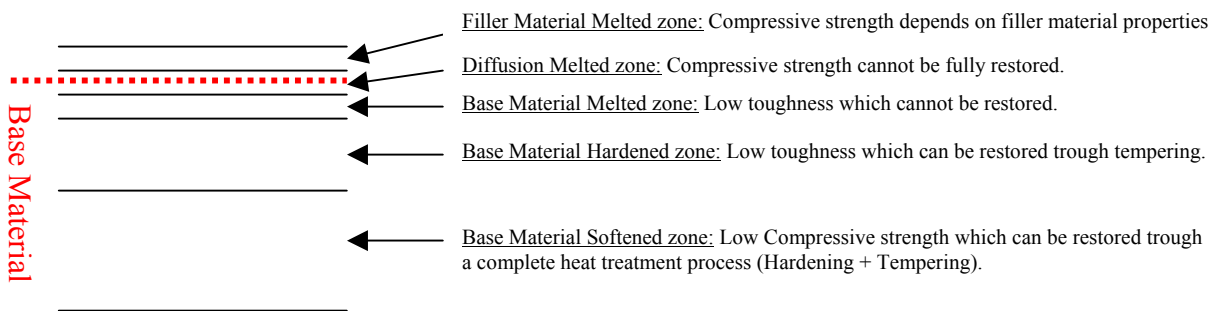

NOT DRAWN TO SCALE

Most of the filler materials lack resistance, and sinking can occur. To completely restore hardness, the whole die should be hardened after welding, but the filler material melted zone and the diffusion melted zone will not reach the same hardness, unless the filler material has a composition similar to the base material. Re-hardening should be done as a post CVD hardening cycle, and given that heat treatment deformation of this material is very low, good results can be attained.

The following procedure has been reported to work by our clients (our laboratory has not finished the research on this matter), although some other clients have reported cracking of the weld bead problems, no cracking of the base material has been reported:

-TIG welding with either HWS or UNIVERSAL as filler material. The piece has to be maintained warm between 350-500 °C reheating when needed. Weld beads should be done at intervals of 20mm, upsetting the bead on every interval. After the weld the die has to be hardened. The structure and consequently the toughness is quite different in the melted zone, but toughness is still higher than that of 1.2379 in that zone.

-Direct welding with a hard electrode like EutecTrode 2R or KD64. The piece has to be maintained warm between 350-500 °C reheating when needed. Weld beads should be done at intervals of 20mm, upsetting the bead on every interval. Cracks on the weld bead are almost unavoidable (it does not depend on the base material but on the filler material itself). After welding the piece should be subjected to a full annealing treatment (slowly heating to 860 °C maintain 2 to 4 hours, and cool down to 650 °C at a speed of maximum 20 °C / hour, maintain at 650 °C during 2 hours and cool down slowly by keeping the die in the oven). Then the die has to be hardened.

Joining and surfacing annealed material:

When using the following filler materials for joining or bead surfacing, cracking occurs on the filler material and not on the heat affected zone once the base material has been hardened, for UNIVERSAL, HWS and 1.2379, so the mechanical resistance of the joint is that of the filler material:

EutecTrode 2, KD 64. (annealing after welding is required)
CartoTIG 45318 W.

The welding procedure should be as follows:

Weld the piece while keeping it at a temperature between 350-500 °C, reheat if necessary. After every weld bead, conduct a post weld upsetting to counter tensions origination from solidification and cooling down. After welding the piece should be subjected to a full annealing treatment (slowly heating to 860 °C maintain 2 to 4 hours, and cool down to 650 °C at a speed of maximum 20 °C / hour, maintain at 650 °C during 2 hours and cool down slowly by keeping the die in the oven).

TIG welding with UNIVERSAL or HWS as filler material is currently being tested.

Joining and surfacing hardened material on dies which have to work right away:

The research has not yet been concluded.

WIRE ELECTRO EROSION:

Given the higher tempering temperature, the dimensional stability during wire electro-erosion is better than that for 1.2379. The intensity and gap time for the wire electro-erosion machine will have to be adjusted, since the optimal parameters for UNIVERSAL, HWS and 1.2379 do not coincide. The hardness does not need to be reduced, unless very high cutting speeds are used and given that the following general recommendations are followed:

-The already heat treated blocks should not be lifted or held with high density magnets containing Nd or other Rare Earths, since the remnant magnetization in the block will make proper removal of burns by the water flow very difficult. A lack of cleanliness will lead to frequent wire breakages and roughness gradients. The lack of cleanliness can be recognized by the dark shaded region appearing on the cut face:

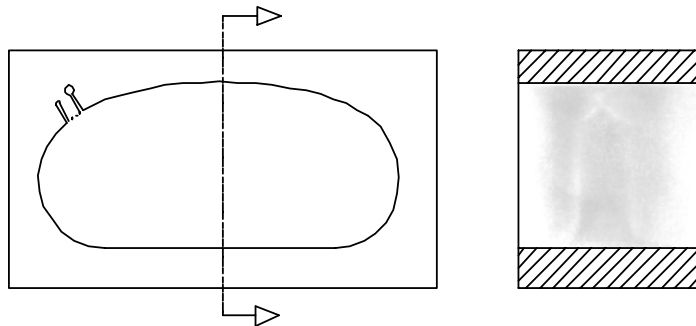

-The cutting speed should not be excessive, since the melted layer (otherwise known as “white layer”) should be kept inferior to 20µm during rough cutting, and inferior to 10µm after the final overhaul. The thermal tensions originated with excessive cutting speeds can lead to the cracking of the block. The material is less sensible to this effect when hardness is 62 HRc or lower, but the effect on the performance of the produced dies is very big and thus such practice is strongly discouraged. This layer should always be eliminated from the die, at least from the working parts of the die. If the white layer is inferior to 10µm this can be done with emery paper. Toughness which is so important when working with AHSS will be greatly improved.

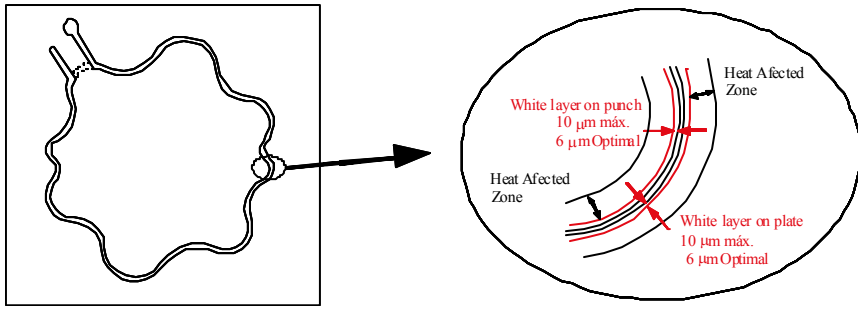

Some microscopic views of the "white layer"

Craters and cracks appear with sharp tips acting as severe stress concentrators. Toughness can be severely reduced

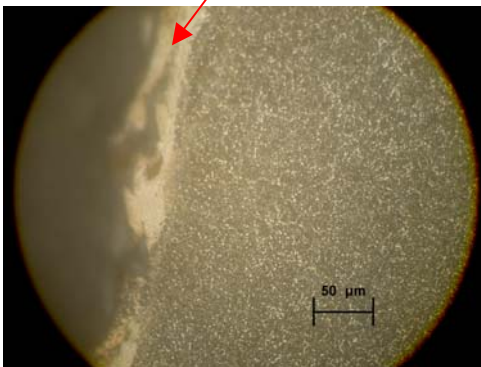

Excessive meted zone thickness
> 20 μm

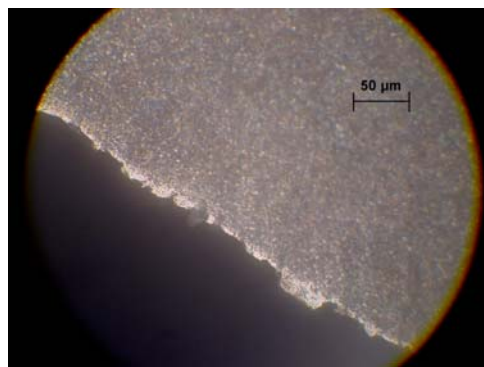

OK meted zone thickness
< 10 μm. EASY TO REMOVE

-After wire electro-erosion cutting, the pieces should be tempered at a temperature 15°C below the highest tempering temperature applied during heat treatment.

Other considerations have to be taken into account when cutting punches with electro-erosion out of a heat treated plate, to minimize the effect of the internal stresses due to severe geometry changes and thermal stresses introduced during cutting:

1- Always start cutting from the interior of the plate:

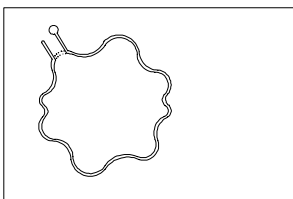

OK

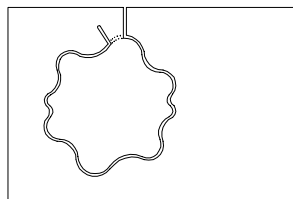

NO

2- Do not start a new cut from the hole of a previously cut piece.

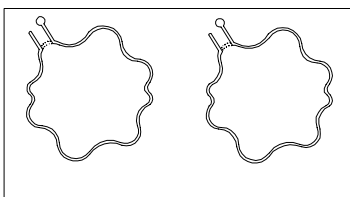

OK

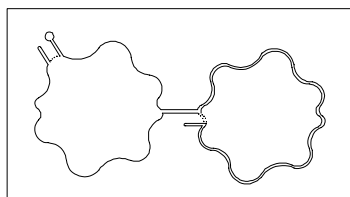

NO

3- The holding frame should have a thickness of at least 4mm, to be able to withstand the internal stresses. The thickness should be bigger if the cut runs quite long along the edge. This same criteria can be applied to calculate the separation between punches.

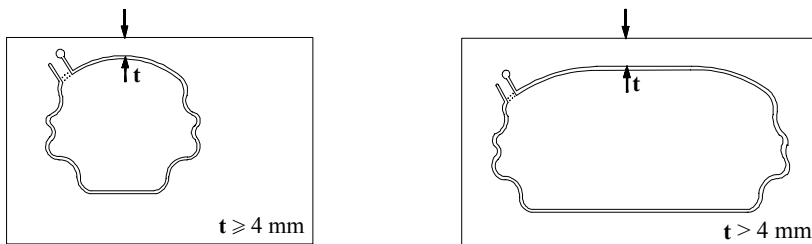

4- When a long perimeter or complex geometry punch has to be cut, several entry points and holding walls have to be employed. The thickness of the walls should be between 4 and 6 mm. In the last overhaul the last wall will be cut, in the before last overhaul the opposite wall will be cut, and so on.

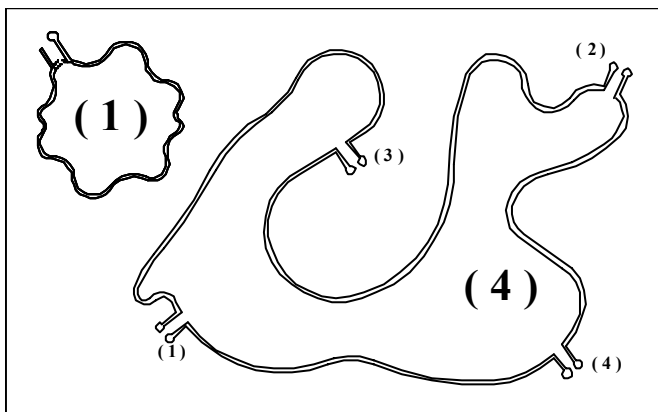

Holding walls cutting order